



Propeller™

www.parallax.com/propeller

What can you do with eight 32-bit processors (COGs) in one chip? Real simultaneous multi-processing! The new Propeller chip is the result of our internal design team working for eight years.

The Propeller chip was designed at the transistor level by schematic using our own Altera Stratix tools to prototype the design. The Propeller is programmed in both a high-level language called Spin™, and low-level Propeller Assembly language. With an ever-expanding set of pre-built Parallax “objects” for video, mice, keyboards, RF, LCDs, stepper motors and sensors your Propeller application is a matter of high-level integration. The Propeller is recommended for those with previous microcontroller experience.

Propeller Chips

Propeller represents the first custom all-silicon product designed by Parallax. For pricing and availability please contact our Sales Department at 888-512-1024 (Monday - Friday, 7 a.m. - 5 p.m., Pacific Time; toll-free in the U.S.).

Propeller Chip	Stock Code	# Pins	Package
P8X32A-D40 Chip	#P8X32A-D40	40	DIP
P8X32A-Q44 Chip	#P8X32A-Q44	44	LQFP (10 x 10 mm)
P8X32A-M44 Chip	#P8X32A-M44	44	QFN (10 x 10 mm)

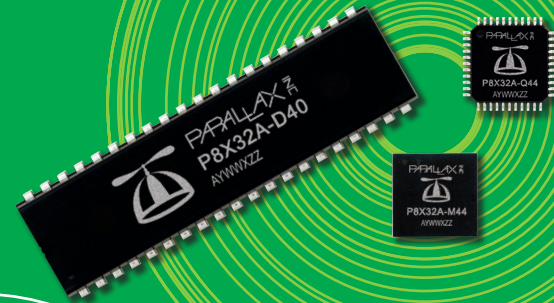

Propeller Chip Specifications

Power Requirements	500 μ A/MIPS @ 3.3 volts DC
External Clock Speed	DC to 80 MHz (4 MHz to 8 MHz with clock PLL running)
Internal RC Oscillator	12 MHz or 20 KHz
System Clock Speed	DC to 80 MHz
COGs	8
Performance	20 MIPS per COG @ 80 MHz
Global RAM/ROM	32 KB RAM / 32 KB ROM
Processor RAM	512 x 32 per COG
I/O Pins	32
Current Source/Sink per I/O	30 mA

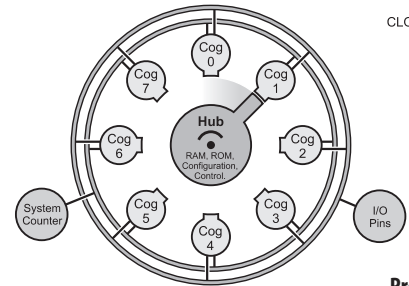
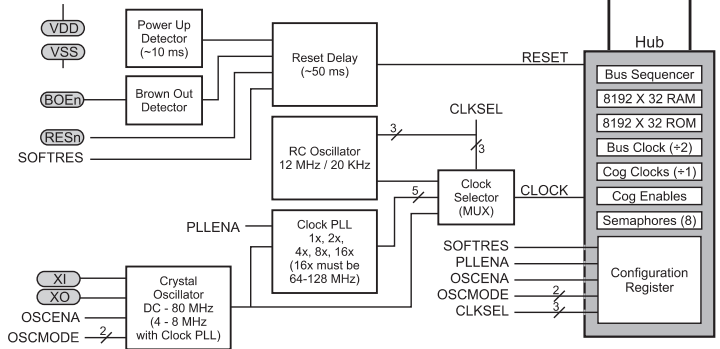
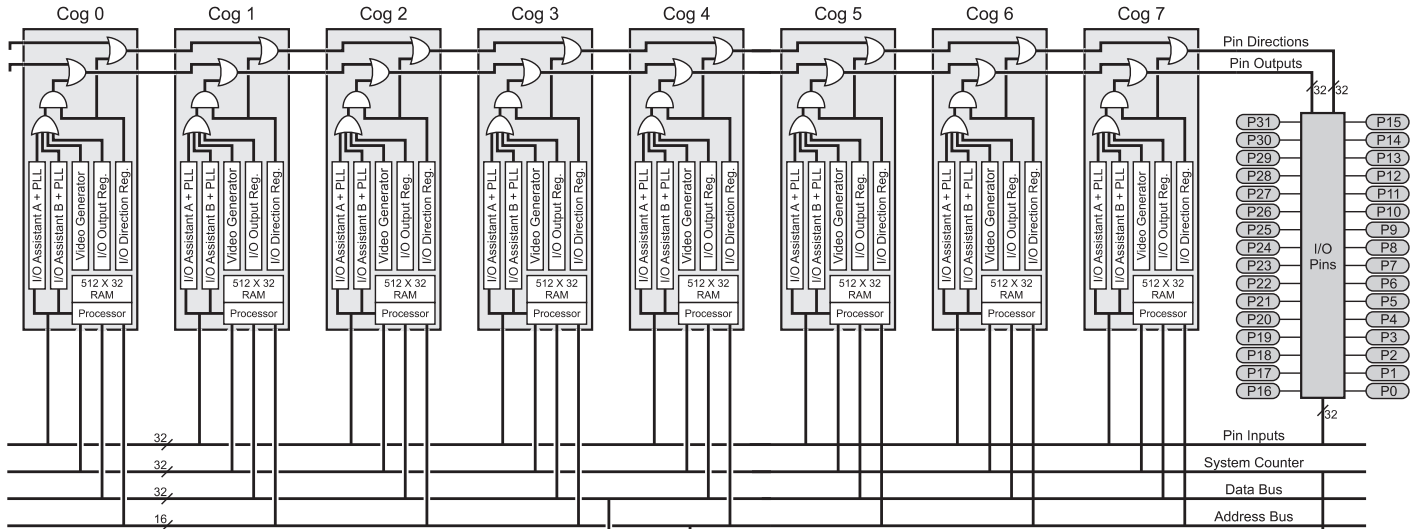

Hub and Cog Interaction

Propeller Block Diagram

(chip pinout diagrams on back cover)

The Propeller IDE - Program in Spin or Propeller Assembly!

The Propeller Tool software allows users to create and use Propeller objects in both Spin™ and Propeller Assembly languages. Multiple objects can be viewed at once for easier development of sophisticated applications. Object documentation is embedded in the source code itself, complete with timing diagrams and schematics, and may be viewed using the Propeller Tool. Applications and their components are quickly explored using the integrated Object View, Object Information, and Source Information displays. Complete applications can be quickly archived to include all their components, and even the Propeller Tool itself, into a single time-capsule file for safe keeping. Compiling and downloading applications to the Propeller chip is a simple operation with the Propeller Tool.

The latest version of the Propeller Tool Software can always be found at our web site (www.parallax.com/propeller). The software is available as a free download compatible with Win2K and above.

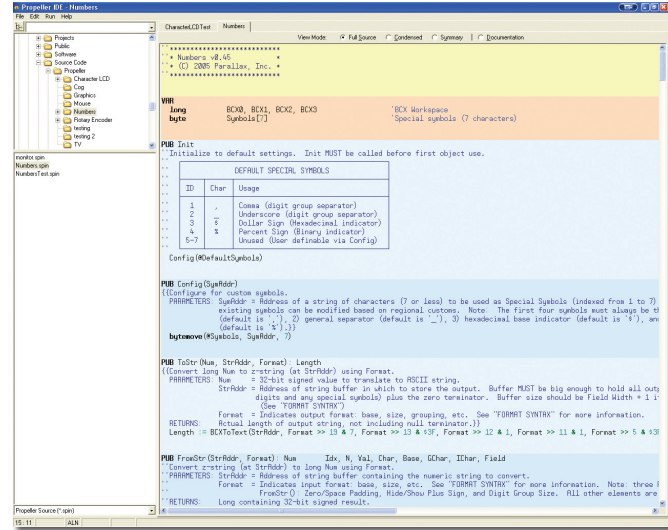

Screen shot of the Propeller Development Tool Software in action.

This Propeller Tool is designed specifically for Windows 2K and later. It relies heavily on a number of operating system-level APIs to achieve many of the demanding goals we had for the software. The Propeller Compiler is written in assembly language for speed in execution. Complex Propeller applications compile, load, and run within a few seconds.

Product	Stock Code
Propeller Demo Board (with power supply)	#32100
Propeller Demo Board (no power supply)	#32101

The Propeller Demo Board, Rev C. visibly demonstrates the Propeller's varied capabilities in a compact and fun platform. You can use it to learn Propeller programming and then develop full-blown applications which generate video and sound, and utilize mice and keyboards (see Propeller Accessories Kit on the following page). All the requisite power supply and USB loading circuitry is provided for you. Eight unused I/O pins are available for experimentation. Kit includes Propeller Demo Board, and a USB A to Mini B Cable. *Note: A Propeller P8X32A-Q44 chip is mounted to the board. All you need to do is plug it in to start programming.*

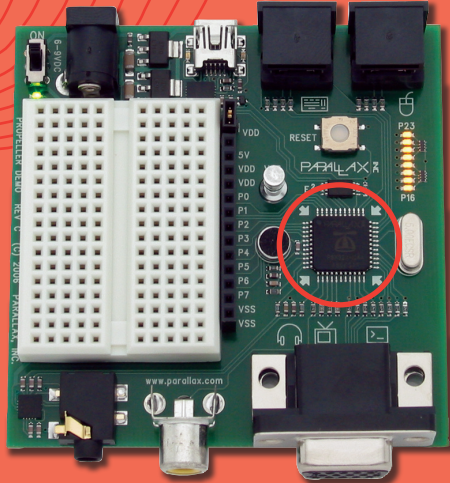

The most comprehensive way to get started with the Propeller chip.

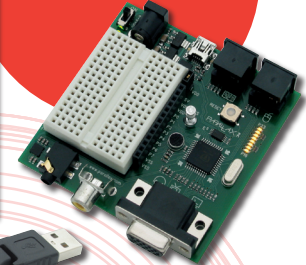

Product	Stock Code
Propeller Starter Kit	#32300

The Propeller Starter Kit contains the Propeller Manual, Propeller Demo Board, and a USB A to Mini B Retractable Cable. Everything you need to program a Propeller chip except for the PC and power supply. Parallax recommends a 7.5V 1 Amp Power Supply (sold separately; #750-00009).

Product	Stock Code
Propeller Accessories Kit	#32311

The perfect addition to your Propeller Starter Kit. This kit contains a 2.5" LCD A/V Display, Parallax PS/2 Mini-Keyboard, and a Parallax PS/2 Optical Mouse; everything you need to see the Propeller chips' capabilities in action.

The 2.5" LCD A/V Display is equipped with a high resolution color TFT LCD. This product is portable and you can bring it anywhere easily. Great for displaying NTSC video from the Propeller Chip or any other device which has an Audio/Video Out connector.

The Parallax PS/2 Mini-Keyboard is a fully functional Windows keyboard providing a compact solution for keyboard entry with the Propeller Chip. This keyboard can also be used on our SX Microcontroller and BASIC Stamp (with appropriate serial encoder chip). Dimensions are 11.81 x 5.91 inches (30 x 15 cm).

The Parallax PS/2 Optical Mouse is a compact, low-profile, optical mouse with three buttons and a scroll wheel. It's small size and PS/2 connection make it a great input device for the Propeller Chip. This mouse can also be used on our SX Microcontroller and BASIC Stamp (with appropriate serial encoder chip).



Components of the Accessories Kit are also sold separately.

Product	Stock Code
2.5" LCD A/V Display	#603-32000
Parallax PS/2 Mini Keyboard	#32351
Parallax PS/2 Optical Mouse	#32350

Propeller Object Library

The key to using a Propeller and having fun is the availability of Objects. Objects provide structure and code reusability. They can be created by one developer and shared with others for use in their projects with or without modification. An Object consists of Spin code and optional Propeller Assembly code. If you've got the right objects, using Propeller is a matter of high-level integration. We invite you to share your Objects in our new Propeller Object Exchange.

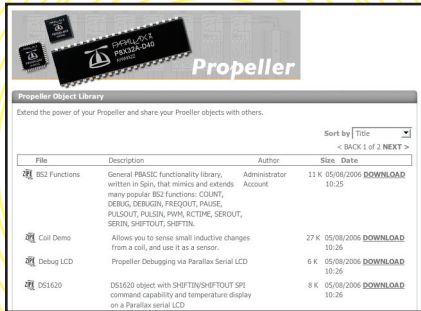

To submit object to the Propeller Object Library users must abide by these rules:

1. Files have no copyright. This is an open exchange among users.
2. No financial payment from Parallax.
3. Parallax will not test your objects.

The Propeller Object Exchange is a user-managed, database-driven area where you can upload and download your objects. In time, this tool will allow searching and sorting (by name, developer's name, keywords, ease of use, user rating, category, etc.).

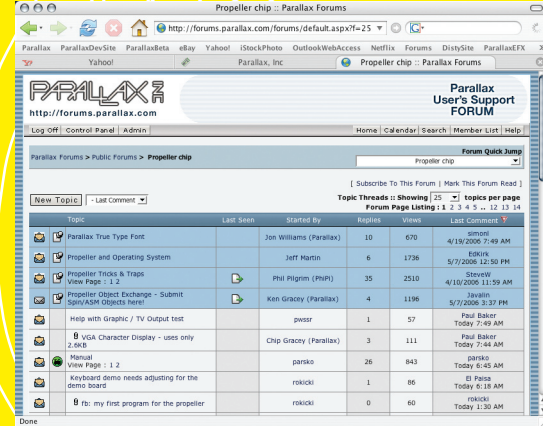

Propeller Discussion Forum

Check out our Propeller Discussion Forum; accessible from www.parallax.com via the Support » Discussion Forums menu. This is an on-line discussion group especially for Propeller users where you can post your questions or review previous discussions that may have already answered yours. The Propeller Discussion Forum welcomes Propeller users ranging from beginner to expert and even includes some Parallax staff members.



Parallax, Inc.
 599 Menlo Drive, #100
 Rocklin, CA 95765
 USA

www.parallax.com/propeller

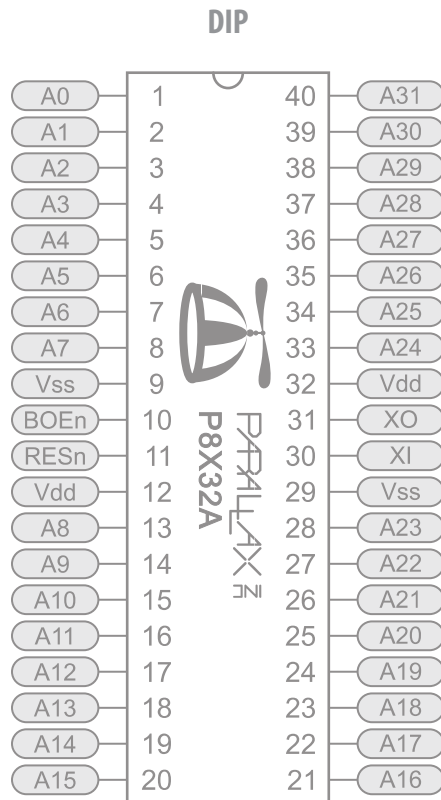
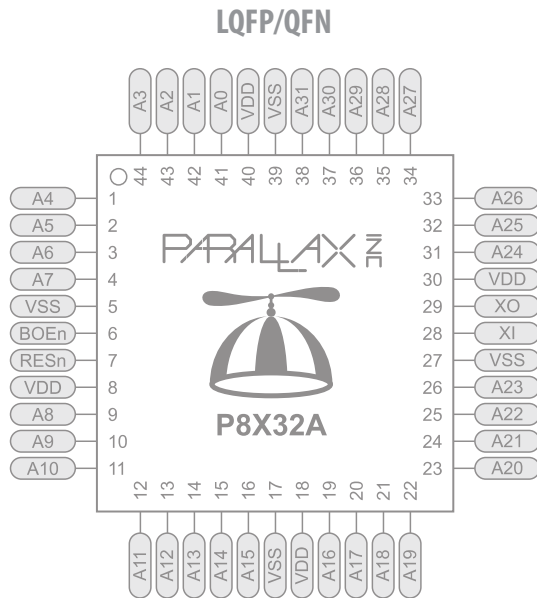

Propeller, Spin, and Parallax are trademarks of Parallax, Inc.
 BASIC Stamp is a registered trademark of Parallax, Inc.

Note: Product description, typographic, pricing, and photographic errors are unintentional and subject to change.